



*Drexel-SDP GK-12 ACTIVITY*

## Activity Template

**Subject Area(s):** Sound

**Associated Unit:** None

**Associated Lesson:** None

**Activity Title:** Doppler Effect: Is it coming or is it going?

**Grade Level:** 8 (7-9)

**Activity Dependency:** None

**Time Required:** 60 minutes

**Group Size:** 2-3 students

**Expendable Cost per Group:** US \$0.00

### Summary:

In this activity, students will discover the Doppler effect through exploring sounds and calculating the frequencies perceived by an observer at each stage of the Doppler effect. As a result, students will learn about the Doppler effect, or the way sound seems to change frequency when coming from a moving object such as a car, airplane, or train. This activity will also provide students with general information about sound waves, including the speed of sound in air and the way the frequency of a sound wave can be represented visually.

### Engineering Connection:

Engineers utilize the Doppler effect in many different fields that range from astronomy, plasma physics, medical imaging, and underwater acoustics. In astronomy, the electromagnetic waves of light are used to determine the velocity at which stars are approaching or receding from the Earth. More directly related to the students' daily lives, as a student rides in the car with someone or drives by a police officer with a radar gun, the officer is checking the speed of the

vehicle using the physics behind the Doppler effect. Sonar systems in the underwater acoustics field use the Doppler effect to determine the direction of a boat or ship that appears on the radar system. All of these examples show that the Doppler effect is quite important and has applications that range from radar as an early warning system in military defense to regulation of the posted speed limit by law enforcers.

**Keywords:** Doppler effect, speed of sound, acoustics, frequency

### **Educational Standards**

Science: 3.4 – Physical Science, Chemistry, and Physics

Math: 2.2 – Computation and Estimation

2.8 – Algebra and Functions

### **Learning Objectives**

After this lesson, students should be able to:

- Explain the Doppler effect and provide examples that occur in their environments
- Calculate the perceived frequency of a moving object producing a sound at all three stages of the Doppler effect (approaching, directly in front, receding)
- Explain how loudness and the Doppler effect are different
- Determine the speed of a moving vehicle given the frequencies from at least two stages of the Doppler effect

### **Materials List**

Each group needs:

- copy of the worksheet
- computer to play sound examples (can be done as a whole class)

To share with the entire class:

- computer to play video examples

### **Introduction / Motivation**

The Doppler effect occurs in the daily environment of most students as they walk to school, ride the school bus, or are sitting inside the classroom, listening to a motorcycle passing by the building or an emergency vehicle's siren whaling. Many students can recognize and determine whether an object making a sound is coming or going but rarely think about the reasons behind this ability. In this activity, students will explore the mathematical equations that explain why we are able to distinguish the general traveling direction of a moving sound source.

## Vocabulary / Definitions

Word	Definition
velocity	the rate of a moving object in a specified direction
Doppler effect	an increase or decrease in the frequency of a wave based on whether the wave source is moving towards or away from the receiver, respectively
frequency	the number of cycles or repetitions per second
amplitude	specifically in acoustics, the loudness of a sound

## Procedure

### Background

The Doppler effect, when dealing with sound, is the change in frequency of the wave heard by an observer that is affected by the relative movement between the sound source and observer. The sound source can be anything making a sound such as a truck's horn, a motorcycle's exhaust, or a subway car. More simply, when the observer is stationary and the sound source is moving towards the observer with the horn blowing, the frequency heard by the observer is a higher frequency than the frequency emitted by the horn. In a sense, the sound waves are being compressed, causing a higher frequency to be heard by the observer. On the reverse end, as the truck with its horn blowing is driving away from the stationary observer, the frequency heard by the observer is lower than the frequency emitted by the horn. This occurs because the sound waves are essentially stretched to create lower frequency sound waves. The frequency emitted by the horn is only heard when the truck is closest to the observer. This relationship can be modeled mathematically with the equation below,

$$f = \left( \frac{v + v_r}{v + v_s} \right) f_o$$

where  $v$  is the speed of sound in air (343 m/s),  $v_r$  is the velocity of the observer,  $v_s$  is the velocity of the sound source,  $f_o$  is the frequency emitted by the sound source, and  $f$  is the frequency heard by the observer. The velocity of a sound source is considered to be negative when moving towards the observer and positive when moving away from the observer. Diagrams of the Doppler effect are shown below for both the case of higher and lower frequencies heard by the observer than that of emitted by the horn.

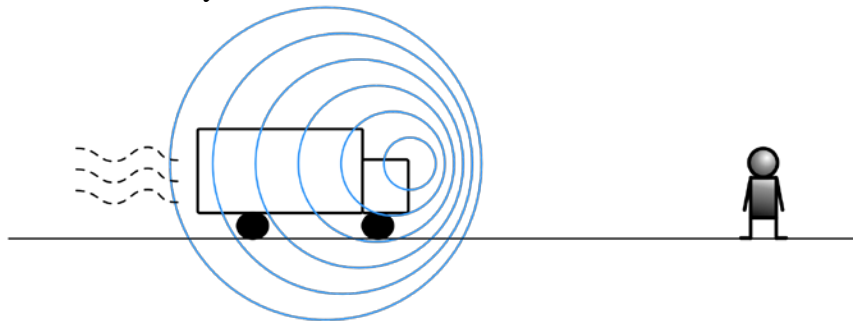

Figure 1: A truck with the horn blow moving towards the observer (higher frequency)

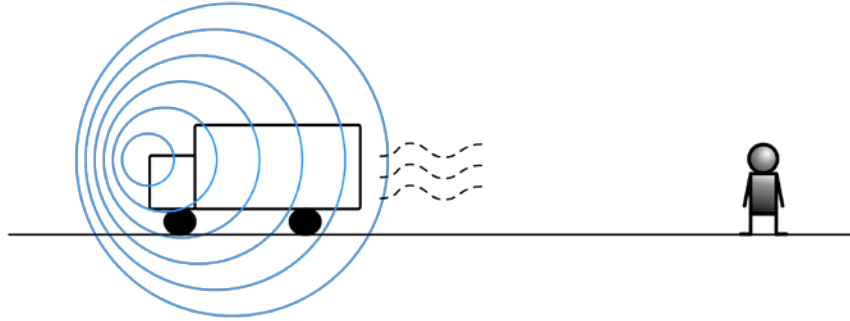

Figure 2: A truck with the horn blow moving away from the observer (lower frequency)

### Before the Activity

- Print out a copy of the lab for each student
- Prepare at least one computer with the sound and video examples to share with the students
- Print out an answer sheet in order to check the students' calculations as they work on the handout

### With the Students

1. Ask the students what they think the Doppler effect is and how they would define it
2. Explain to the students that their job is to determine the frequency heard by an observer when they are given information about the sound source
3. Play this video that demonstrates the Doppler effect with a fire engine siren (<http://www.youtube.com/watch?v=imoxDcn2Sgo>)
4. Ask the students to describe what they heard as the car passed by blowing the horn (Description should be more than just stating that the sound became louder as the car approached)
5. Provide the students with a general background of the Doppler effect that can be taken directly from the Background section
6. Explain to the students that the Doppler effect can be modeled with the equation
7. Put the Doppler effect equation on the board and explain it thoroughly, making sure that students understand what each variable represents
8. Show the students how the equation works by going through a few sample problems covering the various possible situations
9. Present an example of how to convert the rate from miles per hour to meters per second as this will be required knowledge for completing the handout
10. Present the first sample problem with the observer or the sound source stationary, thus having a velocity of 0 m/s for  $v_s$  and  $v_r$
11. Present the second sample problem with the observer stationary and the sound source moving towards the listener, thus  $v_s$  is negative
12. Present the third sample problem with the observer stationary and the sound source moving away from the listener, thus  $v_s$  is positive
13. Provide the students with the handout and have the students work together in small groups of preferably two students, but no more than three students
14. Have the students check with you periodically to see if their answers are correct since the answers are provided below
15. Wrap up by explaining any misunderstandings with the frequency calculations

16. Restate the overall concept of the Doppler effect to conclude the activity

### Attachments

- [Doppler Effect Handout](#)
- [Doppler Effect Handout Answers](#)

### Safety Issues

- None

### Troubleshooting Tips

The calculations can go wrong when the students do not take recognize that velocity,  $v_s$ , is negative for an approaching object and positive for a receding object.

### Investigating Questions

- What other types of waves can the Doppler effect be applied to?
- How does the Doppler effect change other types of waves (i.e., change the color of light waves)?

### Assessment

#### Pre-Activity Assessment

*Class Discussion:*

- Talk with the students about examples of the Doppler effect that they experience on a daily basis (subway car, taxi cab horn, police siren, etc.)
- Have the students describe how the sound of a passing siren changes as the vehicle is moving towards, passes in front of, and moves away from their position (more about frequency than just loudness)

#### Activity Embedded Assessment

*Lab handout/worksheet:* Have the students fill out the Doppler Effect handout and review their answers as a measure of concept comprehension

#### Post-Activity Assessment

None

### Activity Extensions

- The students could research sonic boom and determine its relationship to the Doppler effect
- Have the students research and write a short paper on the application of the Doppler effect in a field of their choice

### **Activity Scaling**

- For lower grades, the intensity of the frequency calculation can be reduced by filling in parts of the equation to help the students complete the formula, such as the values for speed of sound.
- For upper grades, the complexity of detail should include the radial velocity, which takes into account the angle between the observer and the wave source. This changes the calculation of  $v_s$  to be  $v_s = \cos \theta$ .

**Owner:** Drexel University GK-12 Program

**Contributors:** Travis M. Doll, ECE Department, Drexel University

**Copyright:** Copyright 2009 Drexel University GK12 Program. Reproduction permission is granted for non-profit educational use.

## Doppler Effect Calculations Handout

Names: \_\_\_\_\_

### Introduction

---

1. In which picture below would the observer hear a higher frequency?

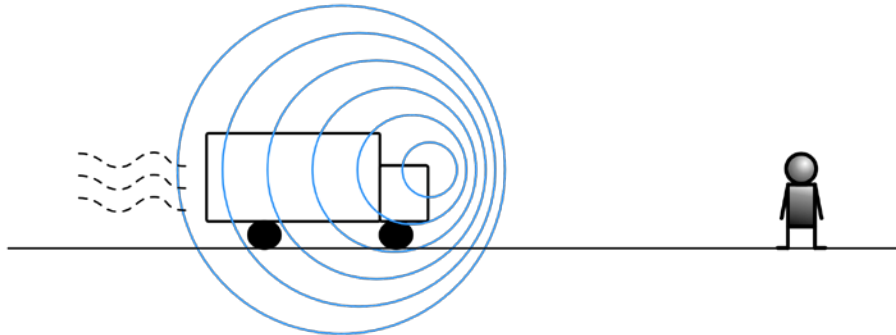

**Approaching vehicle with compressed sound waves.**

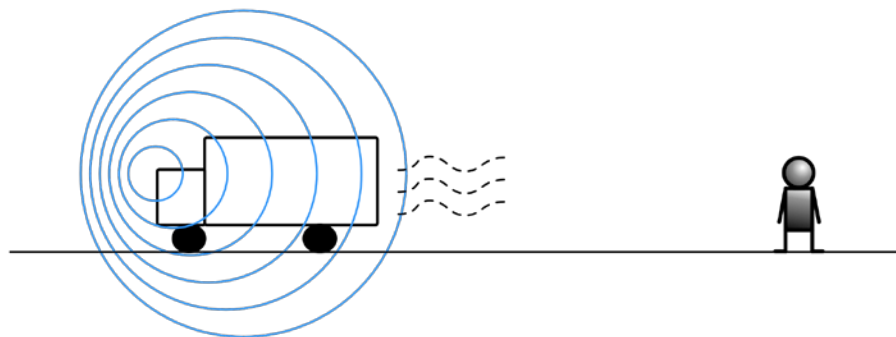

**Receding vehicle with stretched sound waves.**

### Formula for calculating frequencies

---

$$f = \left( \frac{v + v_r}{v + v_s} \right) f_o$$

$v$  = speed of sound in air (343 m/s)

$v_r$  = velocity of the receiver or observer

$v_s$  = velocity of the sound source or truck with a horn

$f_o$  = the frequency of the truck horn

$f$  = the frequency heard by the observer

NOTE: When the vehicle is approaching  $v_s$  is a negative velocity and when the vehicle is receding or driving away from the observer,  $v_s$  is a positive velocity.

## Calculations of the frequency heard when truck is approaching or driving away

---

For each problem below you must do the following:

- Convert the velocity of the moving truck from miles per hour to meters per second for  $v_s$ , where (1 mph = 0.44704 m/s)
- Calculate the frequency heard by the observer as the truck drives towards the observer ( $f_T$ )
- Calculate the frequency heard by the observer of the truck drives away from the observer ( $f_A$ )
- Round your final answer to the nearest hundredth for both  $f_T$  and  $f_A$

1. The truck is travelling at 30 mph and is the horn is producing a 1000 Hz tone and the observer is standing still.

2. The truck is travelling at 60 mph and is the horn is producing a 12000 Hz tone and the observer is standing still.

3. The truck is travelling at 42 mph and is the horn is producing a 1523 Hz tone and the observer is standing still.

4. The truck is travelling at 100 mph and is the horn is producing a 3257 Hz tone and the observer is standing still.



5. The truck is travelling at 72 mph and is the horn is producing a 5000 Hz tone and the observer is standing still.

### Formula for calculating truck speeds

---

$$v_s = v * \left( \frac{f_o}{f} \right) - v$$

$v$  = speed of sound in air (343 m/s)

$v_s$  = velocity of the sound source or truck with a horn

$f_o$  = the frequency of the truck horn

$f$  = the frequency heard by the observer

NOTE: When the vehicle is approaching  $v_s$  is a negative velocity and when the vehicle is receding or driving away from the observer,  $v_s$  is a positive velocity.

### Calculations of the speed of the truck as it is driving towards or away from the observer

---

For each problem below you must do the following:

- Calculate the velocity of the moving truck given the specified values
- Convert the velocity of the moving truck from meters per second to miles per hour for  $v_s$ , where (1 m/s = 2.23693 mph)
- Round your final answer to the nearest hundredth for  $v_s$

6. A truck with a horn that produces a 3333 Hz tone that is heard by the observer at 4000 Hz.

7. A truck with a horn that produces a 15200 Hz tone that is heard by the observer at 15100 Hz.

8. A truck with a horn that produces a 1234 Hz tone that is heard by the observer at 1123 Hz.

9. A truck with a horn that produces a 5225 Hz tone that is heard by the observer at 5350 Hz.

10. A truck with a horn that produces a 9372 Hz tone that is heard by the observer at 9816 Hz.

## Doppler Effect Calculations Handout Answers

Names: \_\_\_\_\_

### Introduction

---

1. In which picture below would the observer hear a higher frequency?

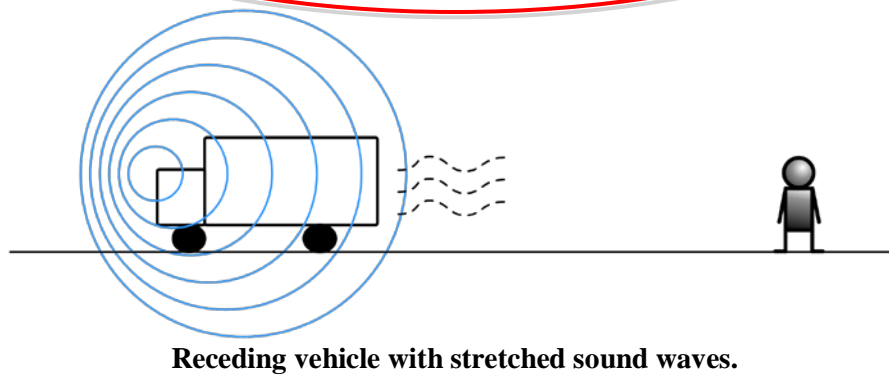
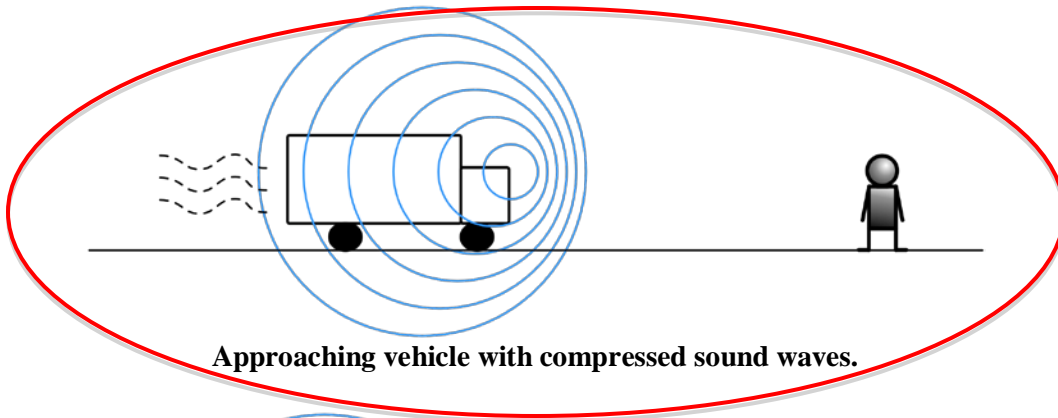

### Formula for calculating frequencies

---

$$f = \left( \frac{v + v_r}{v + v_s} \right) f_o$$

$v$  = speed of sound in air (343 m/s)

$v_r$  = velocity of the receiver or observer

$v_s$  = velocity of the sound source or truck with a horn

$f_o$  = the frequency of the truck horn

$f$  = the frequency heard by the observer

NOTE: When the vehicle is approaching  $v_s$  is a negative velocity and when the vehicle is receding or driving away from the observer,  $v_s$  is a positive velocity.

## Calculations of the frequency heard when truck is approaching or driving away

---

For each problem below you must do the following:

- Convert the velocity of the moving truck from miles per hour to meters per second for  $v_s$ , where (1 mph = 0.44704 m/s)
- Calculate the frequency heard by the observer as the truck drives towards the observer ( $f_T$ )
- Calculate the frequency heard by the observer of the truck drives away from the observer ( $f_A$ )
- Round your final answer to the nearest hundredth for both  $f_T$  and  $f_A$

1. The truck is travelling at 30 mph and is the horn is producing a 1000 Hz tone and the observer is standing still.

$$f_o = 1000 \text{ Hz}$$

$$v_r = 0 \text{ m/s}$$

$$v_s = 30 \text{ mph (13.4112 m/s)}$$

$$f_T = 1040.69070 \approx 1040.69 \text{ Hz}$$

$$f_A = 962.37155 \approx 962.37 \text{ Hz}$$

2. The truck is travelling at 60 mph and is the horn is producing a 12000 Hz tone and the observer is standing still.

$$f_o = 12000 \text{ Hz}$$

$$v_r = 0 \text{ m/s}$$

$$v_s = 60 \text{ mph (26.8224 m/s)}$$

$$f_T = 13018.00001 \approx 13018.00 \text{ Hz}$$

$$f_A = 11129.66656 \approx 11129.67 \text{ Hz}$$

3. The truck is travelling at 42 mph and is the horn is producing a 1523 Hz tone and the observer is standing still.

$$f_o = 1523 \text{ Hz}$$

$$v_r = 0 \text{ m/s}$$

$$v_s = 42 \text{ mph (18.77568 m/s)}$$

$$f_T = 1611.19622 \approx 1611.20 \text{ Hz}$$

$$f_A = 1443.95831 \approx 1443.96 \text{ Hz}$$

4. The truck is travelling at 100 mph and is the horn is producing a 3257 Hz tone and the observer is standing still.

$$f_o = 3257 \text{ Hz}$$

$$v_r = 0 \text{ m/s}$$

$$v_s = 100 \text{ mph (44.704 m/s)}$$

$$f_T = 3745.10889 \approx 3745.11 \text{ Hz}$$

$$f_A = 2881.45338 \approx 2881.45 \text{ Hz}$$

5. The truck is travelling at 72 mph and is the horn is producing a 5000 Hz tone and the observer is standing still.

$$f_o = 5000 \text{ Hz}$$

$$v_r = 0 \text{ m/s}$$

$$v_s = 72 \text{ mph (32.18688 m/s)}$$

$$f_T = 5517.78509 \approx 5517.79 \text{ Hz}$$

$$f_A = 4571.05536 \approx 4571.06 \text{ Hz}$$

### Formula for calculating truck speeds

---

$$v_s = v * \left( \frac{f_o}{f} \right) - v$$

$v$  = speed of sound in air (343 m/s)

$v_s$  = velocity of the sound source or truck with a horn

$f_o$  = the frequency of the truck horn

$f$  = the frequency heard by the observer

NOTE: When the vehicle is approaching  $v_s$  is a negative velocity and when the vehicle is receding or driving away from the observer,  $v_s$  is a positive velocity.

### Calculations of the speed of the truck as it is driving towards or away from the observer

---

For each problem below you must do the following:

- Calculate the velocity of the moving truck given the specified values
- Convert the velocity of the moving truck from meters per second to miles per hour for  $v_s$ , where (1 m/s = 2.23693 mph)
- Round your final answer to the nearest hundredth for  $v_s$

6. A truck with a horn that produces a 3333 Hz tone that is heard by the observer at 4000 Hz.

$$f_o = 3333 \text{ Hz}$$

$$f = 4000 \text{ Hz}$$

$$v_s = -57.19525 \approx -57.20 \text{ m/s (127.94177} \approx 127.94 \text{ mph)}$$

Truck is approaching

7. A truck with a horn that produces a 15200 Hz tone that is heard by the observer at 15100 Hz.

$$f_o = 15200 \text{ Hz}$$

$$f = 15100 \text{ Hz}$$

$$v_s = 2.27152 \approx 2.27 \text{ m/s (5.08124} \approx 5.08 \text{ mph)}$$

Truck is driving away

8. A truck with a horn that produces a 1234 Hz tone that is heard by the observer at 1123 Hz.

$$f_o = 1234 \text{ Hz}$$

$$f = 1123 \text{ Hz}$$

$$v_s = 33.90294 \approx 33.90 \text{ m/s } (75.83850 \approx 75.84 \text{ mph})$$

Truck is driving away

9. A truck with a horn that produces a 5225 Hz tone that is heard by the observer at 5350 Hz.

$$f_o = 5225 \text{ Hz}$$

$$f = 5350 \text{ Hz}$$

$$v_s = -8.01402 \approx -8.01 \text{ m/s } (-17.92680 \approx -17.93 \text{ mph})$$

Truck is approaching

10. A truck with a horn that produces a 9372 Hz tone that is heard by the observer at 9816 Hz.

$$f_o = 9372 \text{ Hz}$$

$$f = 9816 \text{ Hz}$$

$$v_s = -15.51467 \approx -15.51 \text{ m/s } (-34.70523 \approx -34.71 \text{ mph})$$

Truck is approaching